

HW Series Helical™ Wash Systems

Now Available with Oscillation Current™ and monitor and control system for sanitizer

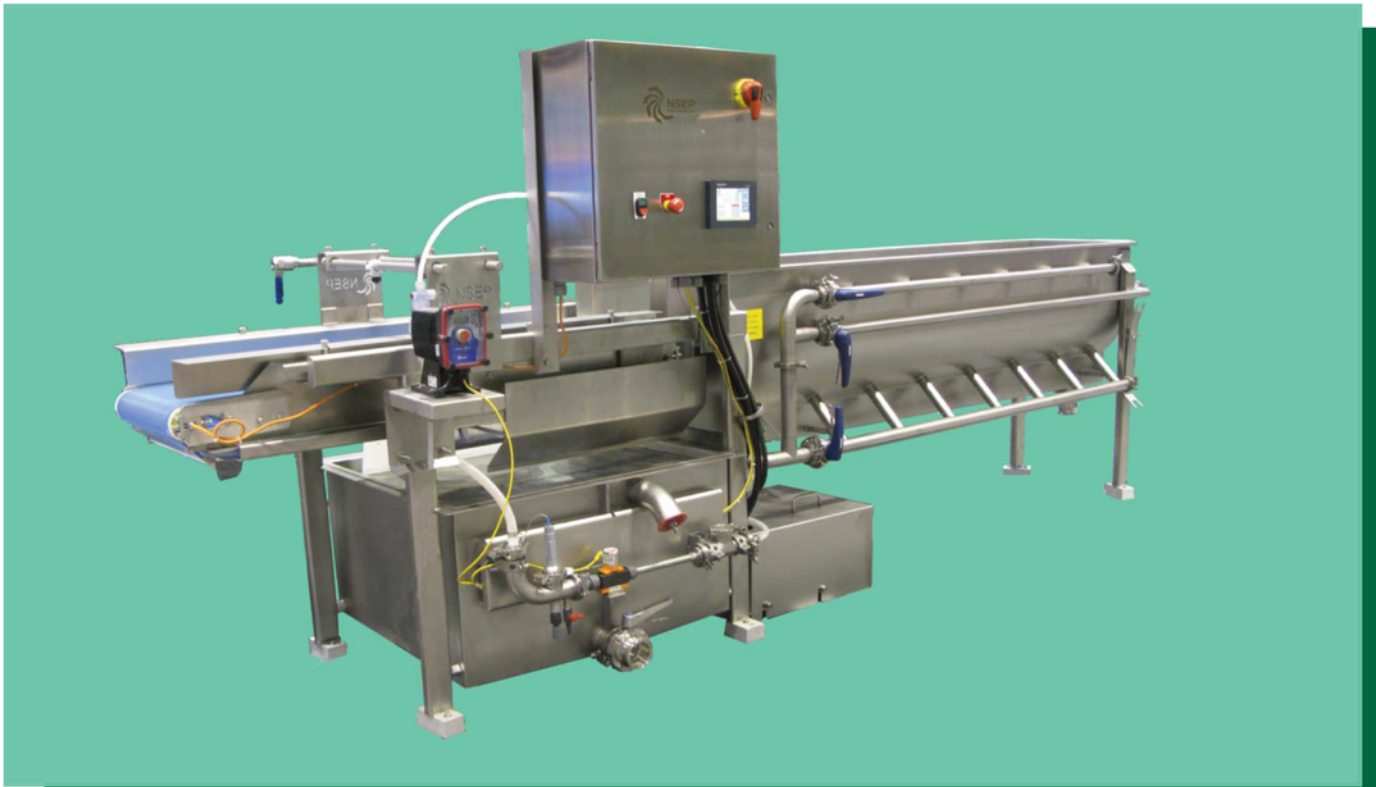

Wash System

Helical™ Wash Systems - gentle, compact washers for root and leafy vegetables (HW3800 System shown above)

The signature HW2600, HW3800 and HW5000 Helical™ Wash Systems from North Star Engineered Products (NSEP) have the unique capability of washing a wide variety of cut and whole product with a maximum wash path in a small space. For example, our HW3800 model contains a 42 foot wash path in just 13-1/5 feet. Its gentle, yet effective action makes it ideal for leafy products as well as root vegetables.

The Helical™ systems come in three models - HW2600, HW3800, and HW5000 - with capacities ranging from 750 to 8,000 pounds per hour.

The Helical™ system effectively separates individual product pieces to ensure full contact with the wash water. Dirt settles in the “quiet” collection trough that runs the length of the wash tank. The double deck shaker separates fines from the finished product. The system is easily disassembled for cleaning.



North Star Engineered Products

Helical™ Wash Systems

SPECIFICATIONS

| Helical™ System | HW2600 | HW3800 | HW5000 |
|------------------------------------|--|--------------------|---------------------|
| Wash Path | 24 feet | 42 feet | 89 feet |
| Length (including shaker) | 119 inches(9' 11") | 162 inches(13' 6") | 207 inches (17' 3") |
| Capacity(based on iceberg lettuce) | 750 lbs. hour | 2500 lbs. hour | 8000 lbs. hour |
| Fill Capacity | 135 gal. | 225 gal. | 400 gal. |
| Total Width | 49 inches | 49 inches | 63 inches |
| Feed Height | 49 inches | 49 inches | 59 inches |
| Discharge Height | 40 inches | 40 inches | 47 inches |
| Total Machine Height | 74 inches (6'2") | 74 inches (6'2") | 81 inches (6'9") |
| Utilities | 20 Amp/10 Amp | 30 Amp/15 Amp | 40 Amp/20 Amp |
| | All models- 230 or 460 Volt HZ / 3 Phase | | |

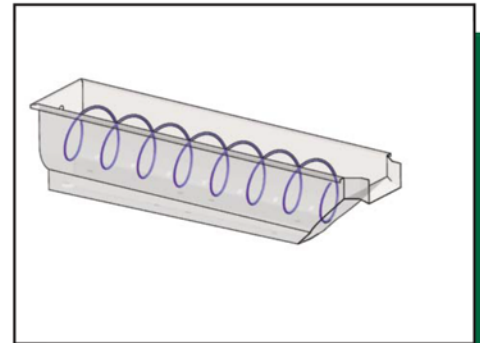

Wash Path Illustration

KEY FEATURES

- ▶ Helical™ wash path - helical action insures complete contact of product with wash water
- ▶ Gentle wash system insures no damage to product
- ▶ Adjustable wash intensity and product retention time
- ▶ Easy connection to a chiller system for maintaining 34 F water temperature
- ▶ Simple connection to ORP/pH monitoring system
- ▶ Replaceable shaker decks with a variety of hole sizes to accommodate various products
- ▶ Removable shaker decks - for ease of cleaning
- ▶ Welded manifolds with sanitary fittings (dairy type) for easy disassembly
- ▶ Sanitary design and large drain valves for easy clean-up and quick changeover
- ▶ Stainless steel construction - including stainless steel valves and electrical box
- ▶ Fresh water final rinse cycle



Sanitary valves and manifold fittings

OPTIONS

- ▶ Falling Film Chiller
- ▶ Oscillation Current Package
- ▶ Integrated monitor and control system for sanitizer

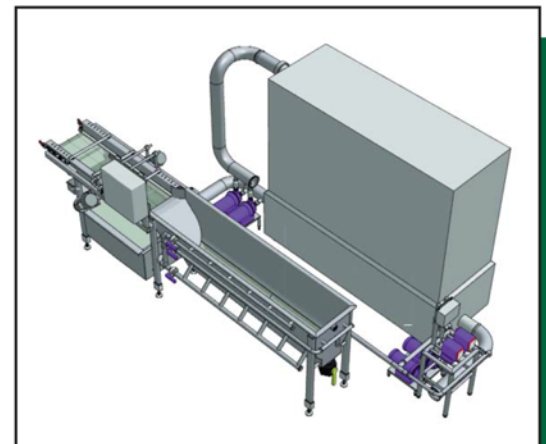

HW3800 with Chiller and ORP System



North Star Engineered Products
28905 Glenwood Road • P.O. Box 1141
Perrysburg, OH 43552-1141 USA

Phone: 419.726.2645 • Fax: 419.726.8583
E-Mail: sales@northstarengineered.com

A Division of Glassline Corporation